



heavy duty refuse  
**ROLL OFF**



*Toughness you can trust.™*

Durable, quality materials and tough “take-no-prisoners” construction. The extra heavy-duty 30 and 40 ton Refuse Roll Offs have been custom designed by DEL to outperform your expectations in even the most demanding environments. The protected single stage double-action reeving cylinder is the perfect solution to your industrial refuse and scrap applications. Backed with the industry leading 60 year commitment to quality, the DEL Refuse Roll Off is the ultimate in reliable toughness and maximum durability.

[www.delequipment.com](http://www.delequipment.com)





Toughness you can trust.™

# heavy duty refuse ROLL OFF

Vancouver

Edmonton

Calgary

Regina

Toronto

Burlington

Montreal

Moncton

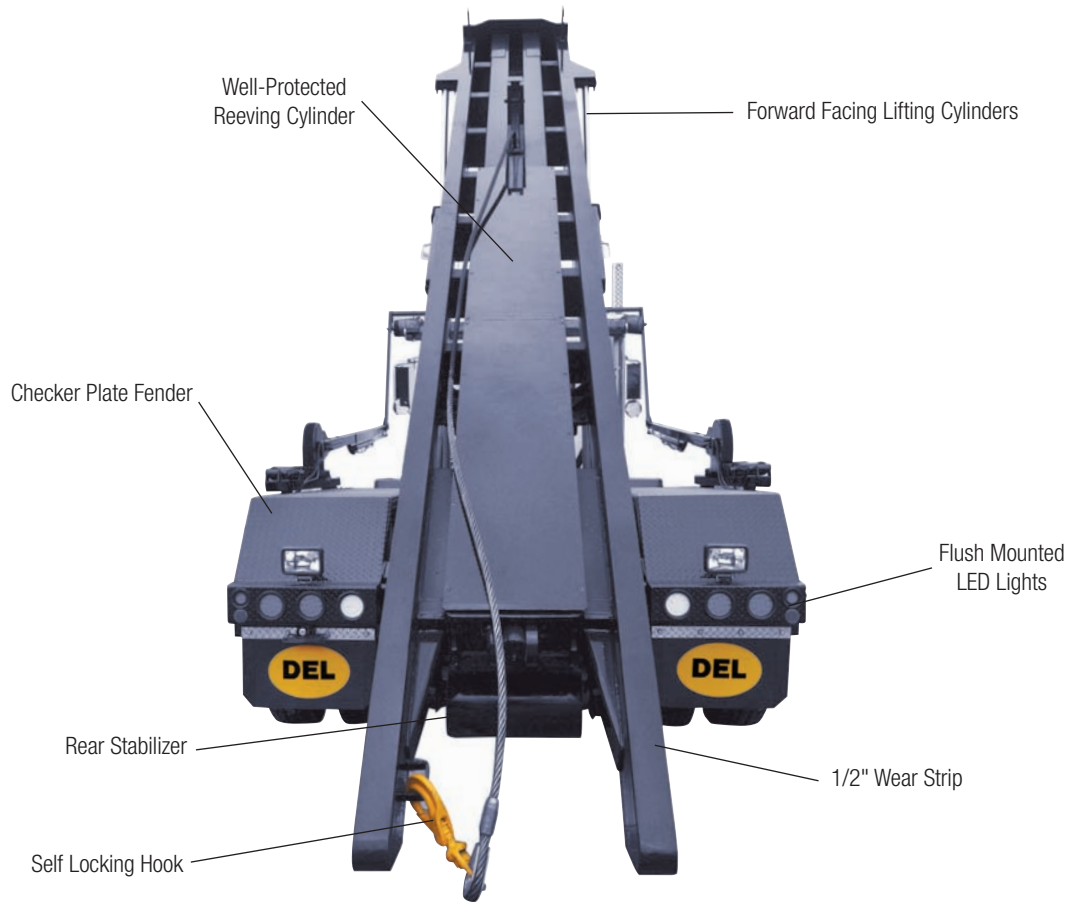

## Features

- Varying section modulus to eliminate frame failure
- 12" x 4" x 0.25" HSS tube with internal reinforcement plates
- Two safety prop rods
- 0.25" Truck chassis wear strip
- Forward facing lifting cylinders
- 8" single stage double acting reeving cylinder
- Reeving cylinder's chromed shaft shielded from the environment (base of reeving cylinder moves vs. shaft)
- Air controls inside cab with hydraulic lever controls outside cab
- LED lights
- Checker plate fender construction
- Rear conspicuity tape
- Zerk fittings at wear points
- Standard transmission mounted PTO/pump hydraulics
- Comprehensive limited 3 year warranty on defects in material and workmanship

## 30 Ton Specifications

- 23.5', 24.5', 26' long tipping frame
- 0.5" x 3" wear strip
- 7/8" Cable, 6X36 IWRC cable self-locking hook
- Forward facing single stage double acting lifting cylinders with 5.75" bore diameter (23.5' unit configured with rearward facing 6.75" bore diameter)

## 40 Ton Specifications

- 24.5', 26' long tipping frame
- 0.5" x 4" wear strip
- 1" Cable, 6X36 IWRC cable self-locking hook
- Forward facing single stage double acting lifting cylinders with 6.75" bore diameter

## Common Options

- Powered rear stabilizer
- Air tarp system
- Side rollers
- Tool/Tarp box
- Lift axle fenders
- PH400 pintle hook
- Auto transmission PTO/pump or front mounted pump hydraulics



HSS Construction with Heavy Internal Reinforcement

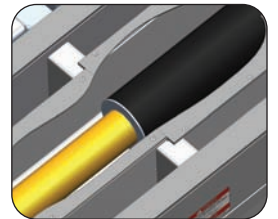

Single Stage Double Actuating Reeving Cylinder with Protected Chrome Rod



Forward Facing Tipping Cylinders for Better Lifting Efficiency



Pusher for Low Head Height Discharge Applications

Due to continuous product improvements, specifications may change without notice. Contact your local vehicle dealer for pricing and availability.

1.866.613.0068 [www.delequipment.com](http://www.delequipment.com)  
email: [sales@delequipment.com](mailto:sales@delequipment.com)